

THIS DRAWING MAY NOT BE USED FOR ANY PURPOSE OTHER THAN BY THE OWNER. THE DRAWING & DESIGN ARE PROPERTY OF ROTONICS MANUFACTURING, INC. ALL DIMENSIONS SHOWN ARE OUTSIDE PART DIMENSIONS IN INCHES, AND MAY VARY DUE TO MATERIAL SHRINKAGE. SPECIFICATIONS ARE SUBJECT TO CHANGE WITHOUT NOTICE. GALLONS AND WEIGHTS ARE APPROXIMATE ONLY.

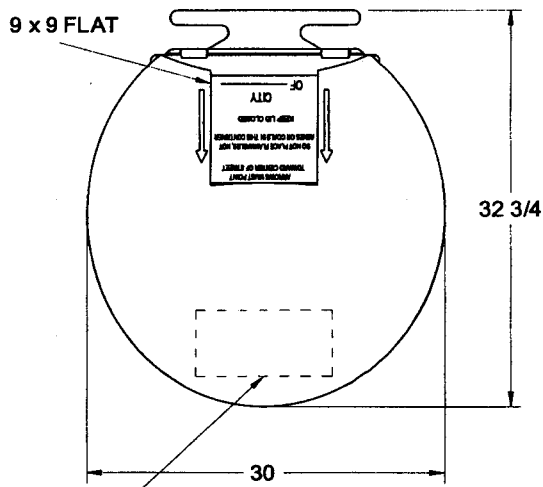

5 1/2 x 11 1/2 SMOOTH AREA

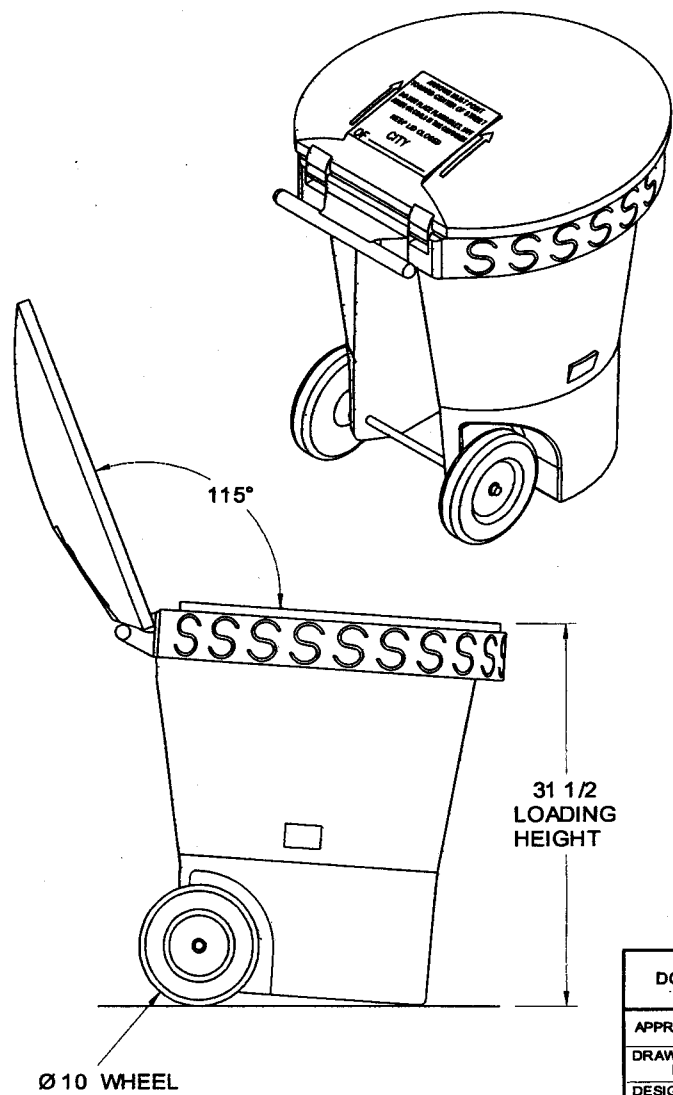
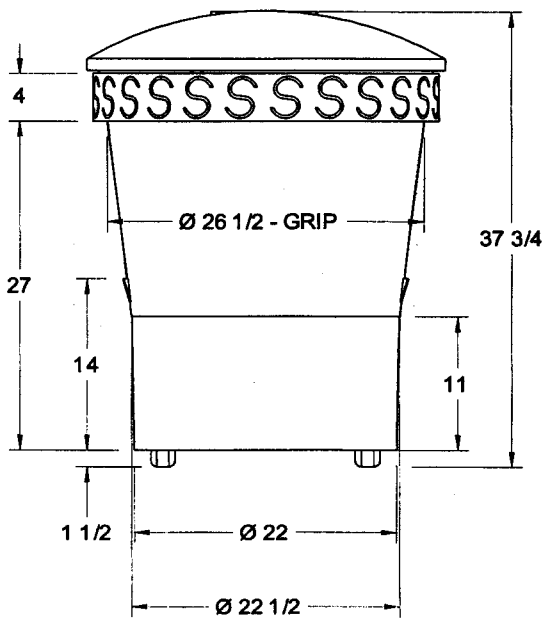

LID IS DOUBLE WALL

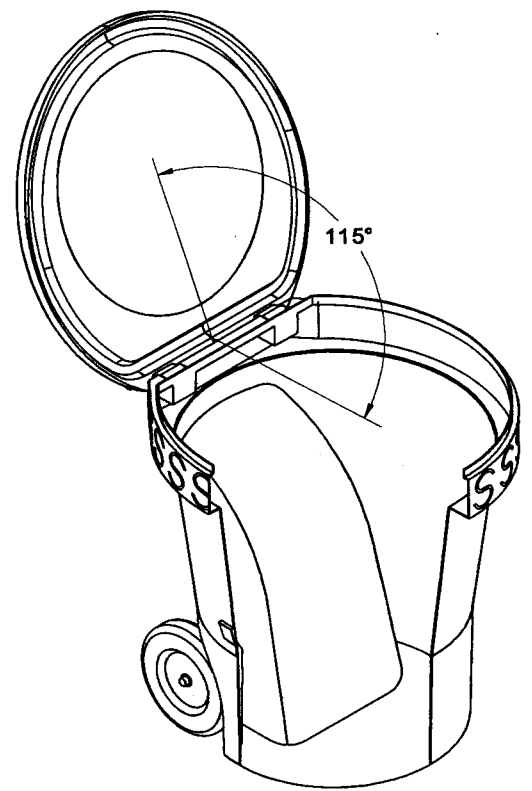

DO NOT SCALE		ROTONICS MFG. INC.		17038 S. FIGUEROA ST. GARDENA, CA. 90248 Phone: (310) 327-5401 Fax: (310) 323-9587	
APPROVALS	DATE	40 gal REFUSE CONTAINER			
DRAWN BY: DPHAM	8/29/03				
DESIGN BY: DPHAM					
CHECKED BY:					
APPROVED BY:		SIZE A	DWG. No. S-1446	REV.	
SCALE: 1 = 16			SHEET 1 of 1		